

13. Circuit Description

13-1 Overall Block Description

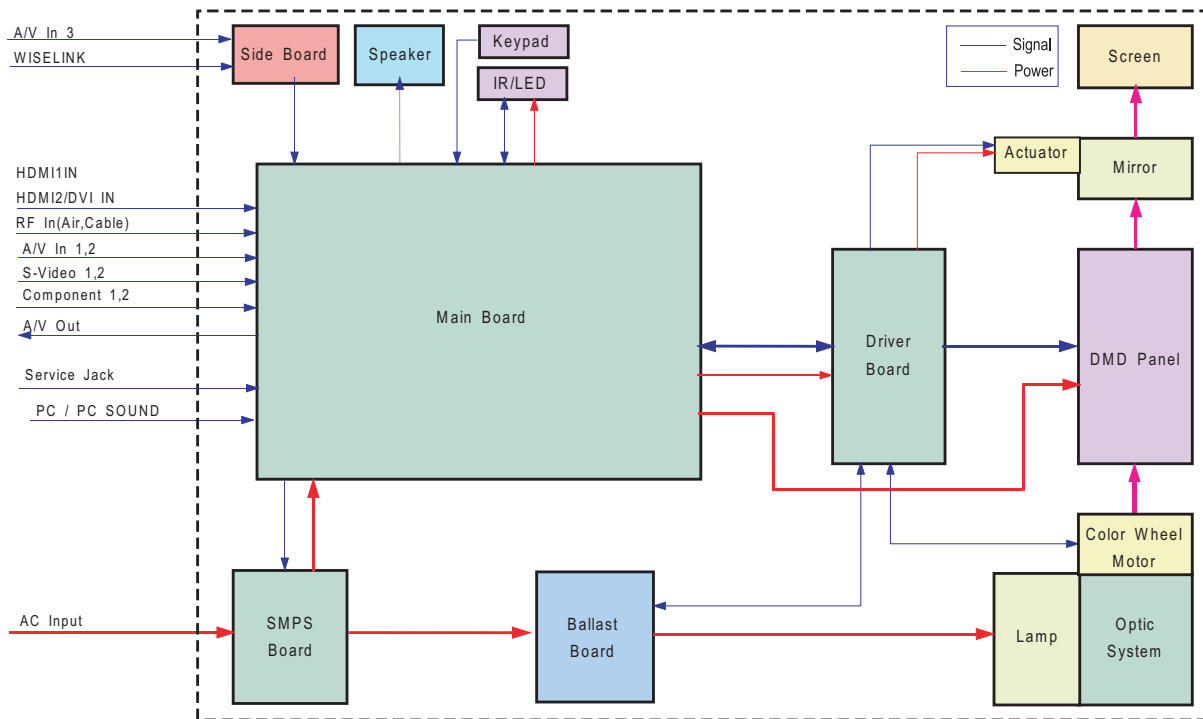

The ass'y that consists of the DMD board, Detect (Actuator) board, lamp, ballast and optical devices is called the Engine.

The Main board part receive the AV signals to output voice signals and process the remote control signals.

The engine part displays the video data on the screen, which is generated in the Main board.

The AV signals are input through the Main board. X240&MST3389 process the MUX and decoding and X240H processes the CPU functions, MPEG and I2S.

Finally, the improved DNle image is sent to the DMD engine board.

The final data by DNle is processed in DDP3021 of the DMD board to display the image on the DMD panel. This image is created by the light of the lamp through the color wheel which is enlarged and projected onto the screen.

This is the DLP of the K2 type that the actuator operates additionally during this process.

The power terminal generates the DC power needed for the product and sends it to the Main board. The Main board supplies the power to the DMD board.

In the meantime, the power source board supplies DC220v - 400v directly to the ballast in order to light the lamp.

The ballast is like a stabilizer for lighting the lamp.

The ultimate purpose of the TV set is to project an image onto the screen and output the voice signals synchronized with the image. And based on the DMD panel used, a 1-panel TV requires a color wheel while a 3-panel TV does not. The HD5 panel needs an actuator while the HD2 does not. However, the drive mechanism and the overall block structure of the two panels are the same.

13-2 Partial Block Description

13-2-1 SMPS Block Description

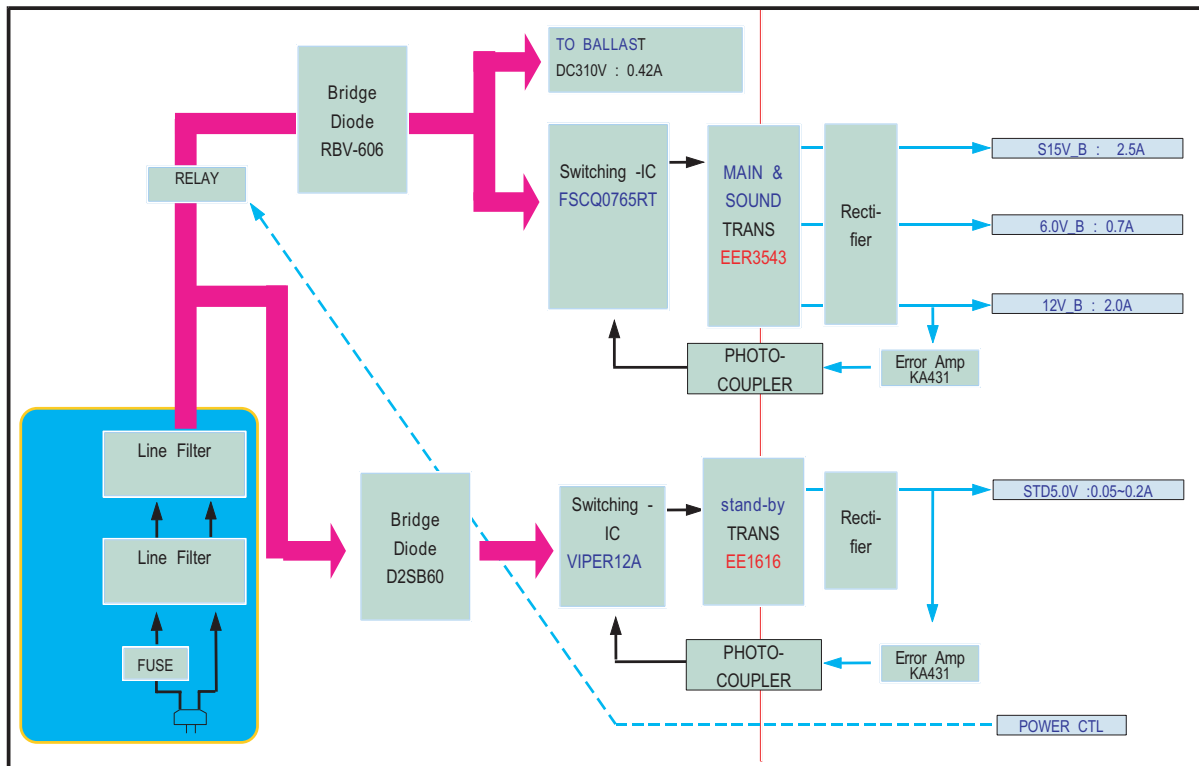

1. What is SMPS?

This is an acronym for Switching Mode Power Supply and this is responsible for receiving AC input voltage (Line frequency: 50HZ~60HZ) and supplying insulated DC output.

2. SMPS Components

- 1) Standby Power: A combination of ICS801 (SWITCHING IC) and TS801S (TRANS) that supplies STAND-BY 5V for operating the Micom.
- 2) Multi Power: The voltage supplied when the power is turned on.
It is a combination of IC801S and T801S that supplies various voltages including 12V_B, 6.0V_B, S15V_B.

3. SMPS Operation

- 1) SMPS System: Uses Fly-Back technology for both standby and multi power.
- 2) Operation: Fly-Back is one of the most popular power-supply systems and uses less power than 200W as well as being the cheapest of all multi output SMPS systems.

Let's have a look at how it operates...

- a. Converts AC input into DC (HOT) (rectifies to DS801 before smoothing to CS801)
- b. The converted DC voltage is high, especially compared to ground, so touching it will cause electric shock.
Use T801S (Trans) to insulate the secondary voltage and take advantage of the PWM operations of T801S and IC801S to induce it.
- c. The secondary induced voltage is 66KHz square wave power, which goes through the smoothing cap (CS822) to be generated in the standby 5V.
- d. Multi power also operates the same way.

4. Input&Output voltage

- 1) Input voltage
 - * America(AC120V) - OPTION
 - * Korea(AC220V) - OPTION
 - * The others(AC100V~AC240V) - OPTION
- 2) Output voltage
 - * 12V_B / 2.5A - 12V , 3.3V , 1.8V : For signal processing
 - * 6.0V_B / 1A - For driving the tuner
 - * -For driving sound amp

13-2-2 Digital Block Description

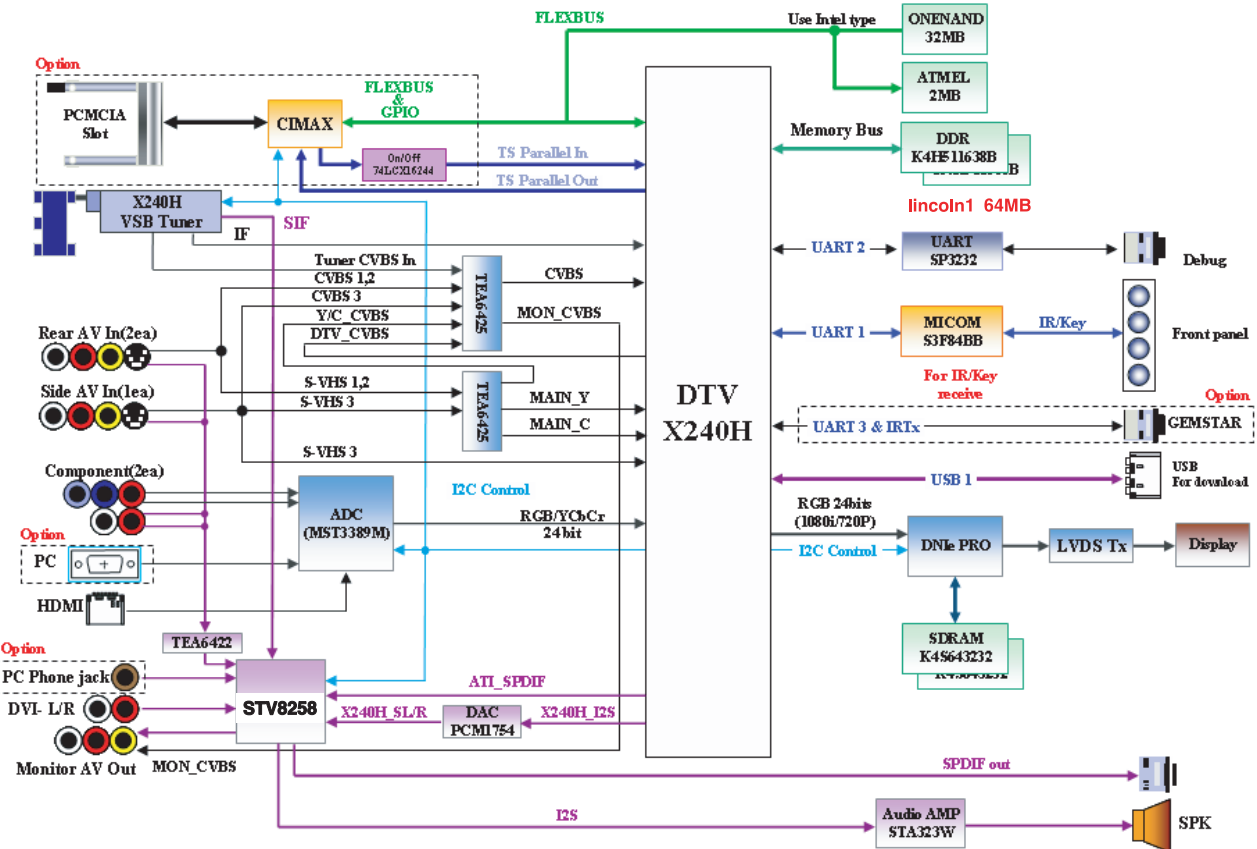

- TEA6425 : TUNER_CVBS, AV, S-VHS INPUT MUXING AND SWITCH
- MST3389 : 2 ANALOG Y/Pb/Pr, 1RGB PC SIGNAL, 2 HDMI RECEIVER
- STV8258 : AUDIO PROCESSOR
- PCM1754 : AUDIO DAC, I2S INPUT SIGNAL AND TRANSFERS IT TO STV8258 IN L/R SIGNAL
- X240H : CPU, +MPEG DECODER, IF DEMODULATOR, AUDIO SIGNALS TRANSFERRED TO PCM1754 BY I2S
- DNIe : USES A NOISE-FILTERING AND PICTURE QUALITY IMPROCEMENT ALGORITHM TO IMPLEMENT NATURAL COLORS
- OTHERS : ANYNET IMPLEMENTATION, OPTICAL PORT, USB UPDATE PORT(NOT AVAILABLE FOR MP3)

The HLS5686W board contains HD tuners to implement analog as well as digital signals from air/cable broadcasting. It decodes Y PB PR and HDMI inputs using MST3389 Mstar chip, which is transferred to X240H (ATI), a combination of the main CPU and the MPEG decoder.

All video inputs are transferred to X240H for digital processing and all video output goes through DNIe to the DLP DMD board.

Audio signals are transferred to the STV8258 chip and are emitted through the speaker.

It also has a 5.1 channel optical port and a USB port for Wiselink and a S/W update

13-2-3 DMD Block Description

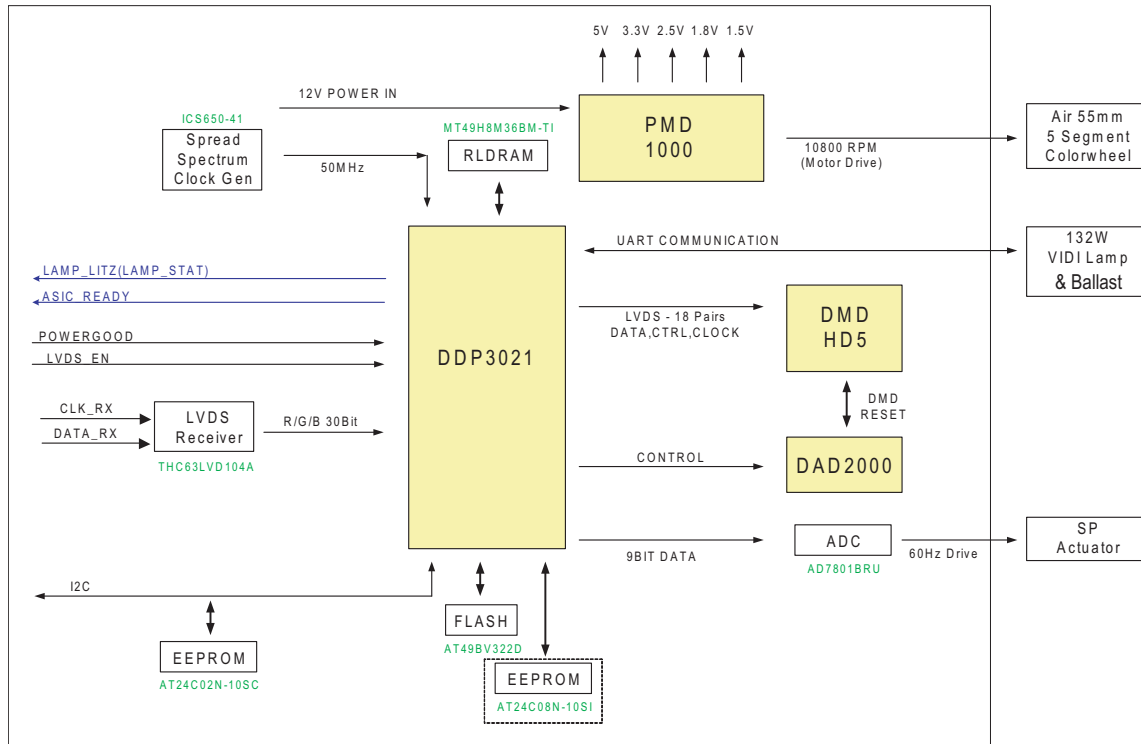

■ TI Chip Set

- Controls the lamp (ON/OFF)
- Drives the color wheel motor
- Drives the panel

13-3 New Circuit Description

13-3-1 Output Voltage States of the DMD Board Parts

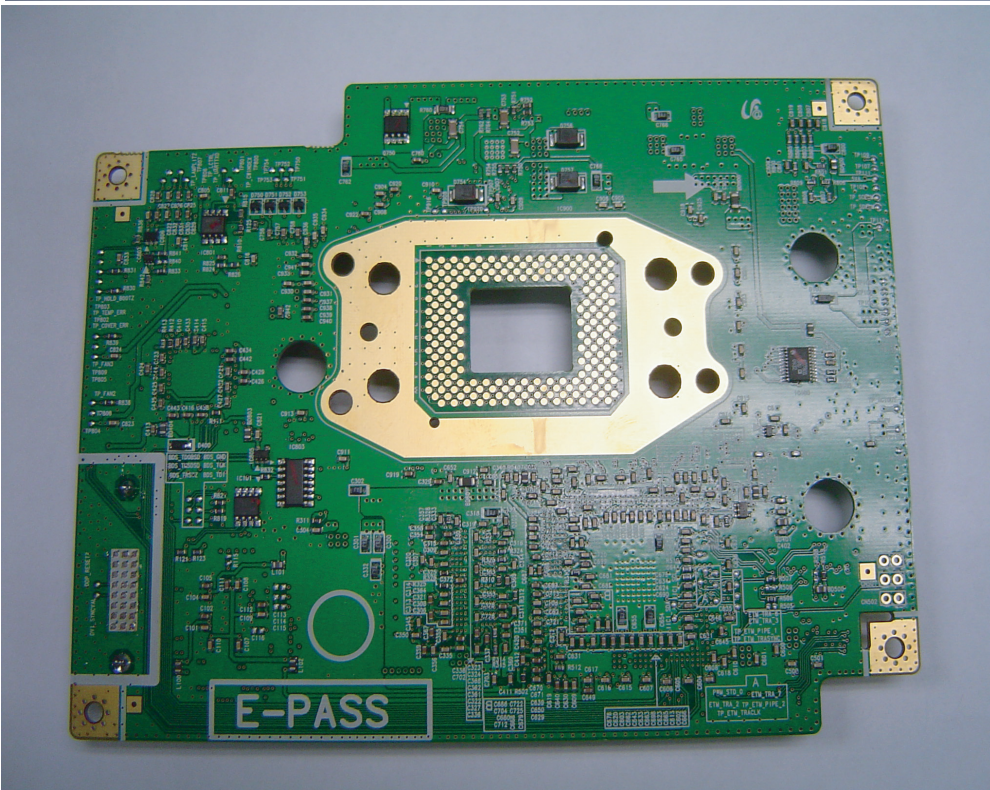
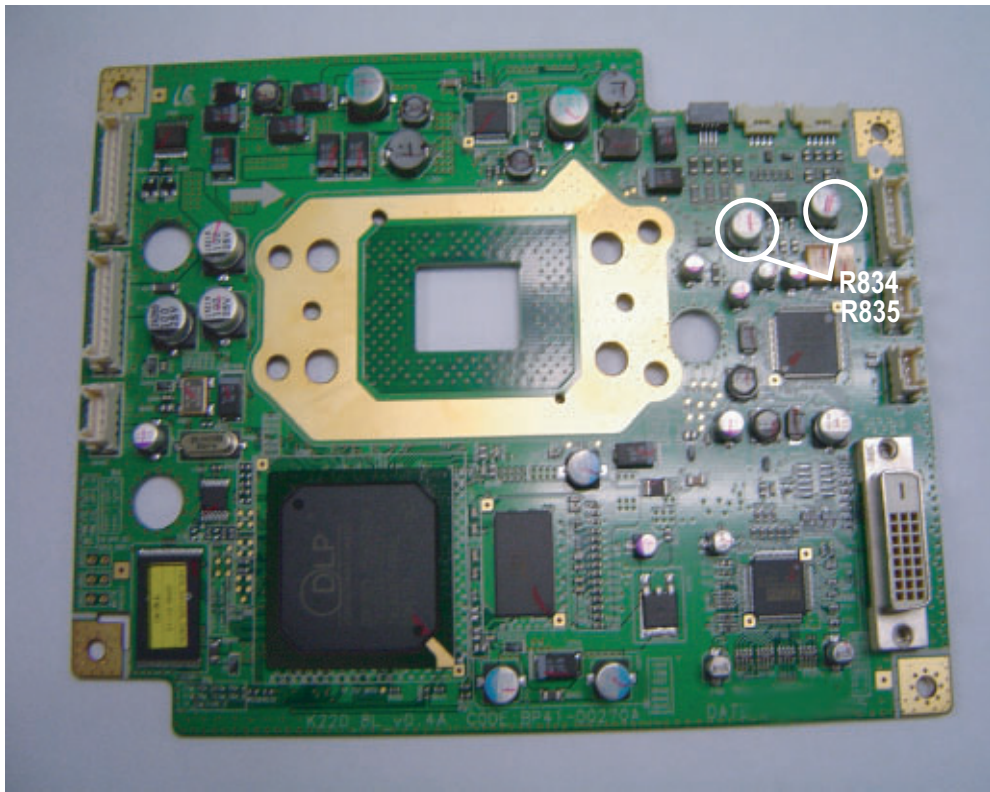

Loc.	Characteristics	
R835	LAMP EN	High from DDP3021
R834	LAMP LITZ	High (5V) before the lamp turns on. Low (0V) when the lamp turns on.

13-3-2 DMD Panel Pin Terminal Characteristics Diagram

※ Remove the heat sink attached to the DMD Board and tighten the screws in four places and then inspect the characteristics of each pin terminal.

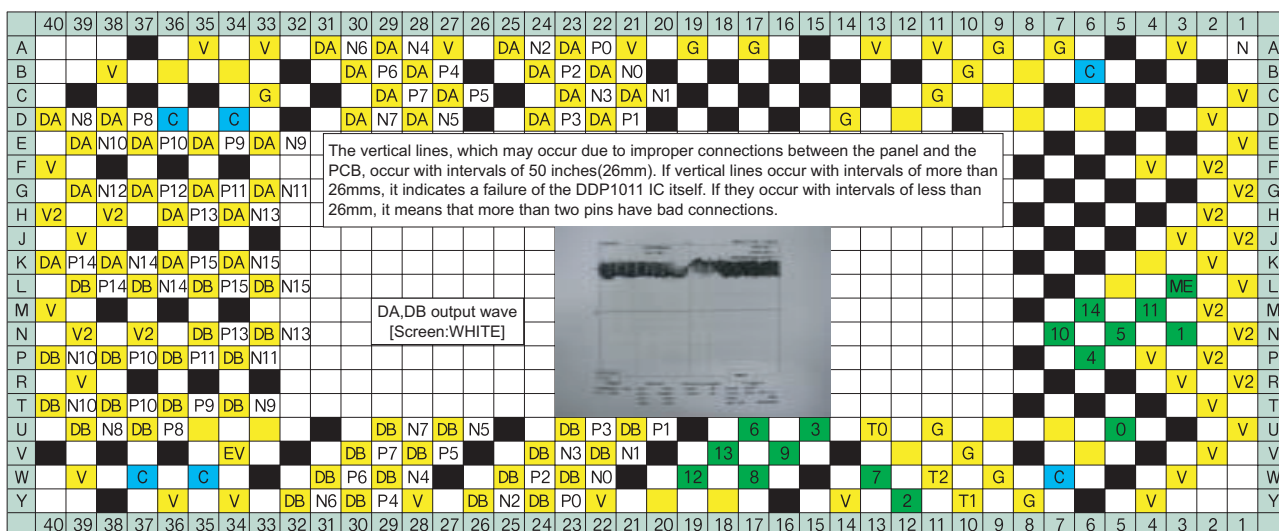

Pin Name	Description	Pin Name	Description
V	Voltage : 3.3V	T	Test Point
V2	VCC2 : 8V	ME	Mirror Bias Extra
DA	A Channel Data Bus [When measured, there should be a waveform]	C	Clock
DB	B Channel Data Bus [When measured, there should be a waveform]	P#	A,B Channel Positive
NO.	MBRST# (Mirror Bias Rest) 26V	N#	A,B Channel Negative
G	The part from the present position to the GND (The black part is also a GND.)		

13-3-3 Description of Terminal Characteristics

Pin Name	Description
SCTRL_AN/P	
DCLK_AN/P	
SCTRL_BN/P	B channel LVDS serial control
DCLK_BN/P	B channel LVDS CLOCK
SCPDI	SERIAL CONTROL DATA INPUT
SCPDO	SERIAL CONTROL DATA OUTPUT
SCPENZ	SERIAL CONTROL ENABLE
SCPClk	SERIAL CONTROL CLOCK
DWRDN	DMD LOGIC RESET
MBRST(14:0)	MIRROR BIAS RESET
MBRST_EXTRA	UNUSED MIRROR BIAS RESET
EVCC	REFERENCE VOLTAGE DURING SPAM READ TEST OPERATION(NORMAL GND)
VCC2	MIRROR ELECTRODE VOLTAGE(8V)
VCC	LOGIC SUPPLY
VSS	LOGIC GROUND

13-3-4 Engine Failure Inspection Flow Chart for the DMD Board

No.	Description	Key Point	Remark
1	1) When the power cord is plugged in, 2) DC 300V~330V is automatically supplied to the ballast.	Check whether the DC 330V power is supplied to the ballast.	
2	1) When the power key is pressed via the remote control, the micom of the analog board outputs high (5V) PWR signals. 2) The power board operates normally. 12V is supplied to the DMD CN101 terminal.	Check whether 12V is supplied to the CN101 terminal.	* 12V must be supplied to operate the motor.
3	1) The power good signal is supplied to pin no.2 terminal of the IC804 from the micom on the digital board and then the motor starts to drive. 2) If the color wheel rotates for a certain time and then stops, check whether the color wheel sensor is normal. (Check the waveform on the No.2 terminal below CN800.) 	After the set is powered on, check whether 5V is detected on pin No.2 of IC804. → After a while, the sound generated by the rotating color wheel is heard.	* If 5V is not detected, the motor will not operate.
4	1) Check whether the signal (SCI: START CONTROL INPUT) that turns on lamp #4 of CN802 on the DMD board is high (5V).	Check whether CN802 #4 signal is 5V.	* When SCI is high (5V), the lamp litz of CN803 is low (0V). * CN803 #4 terminal voltage changes to pulse wave form 14 seconds after (for 50 inch TV) the time that the voltage is 5V. * When about 4 seconds have passed after changing to pulse waveform, the screens are displayed on the set.

13-3-5 IC Line Up

1. Power Board

Items	Descriptions	Remarks
Main SMPS	FS7M0880, Fairchild	IC-PWM Controller ; Main Power
Stand-by SMPS [America]	KA1M0565, Fairchild	IC-PWM Controller ; Stand-by Power
Stand-by SMPS [Korea]	KA5M0165, Fairchild	IC-PWM Controller ; Stand-by Power

2. Digital Board

Items	Descriptions	Remarks
MPEG2 Decoder	X240H	CPU(MIPS), TS Demux, MPEG2 Decoder, Format converter, Deinterlacer, Scaler, USB
ADC HDMI Receiver	MST33389	ADC Digital Receiver for HDMI with HDCP
Video Enhance	SDP32	SAMSUNG RGB Processor
Program ROM	AT49BV + KFG5616U1M	8M + 32M, Nor + ONENAND Flash Memory
Frame Buffer	SDP32 SAMSUNG	RGB Processor
Program ROM	AT49BV x 2	32M(1M x 16) x 2, Nor-Type Flash Memory
Frame Buffer	64MB DDR, 16M Samsung	Frame Memory
LVDS Transmitter	DTC34LM85A	DOESTEK
VIDEO SWITCH	TEA6425	VIDEO SWITCH IC FOR TV (X2)
AUDIO SWITCH	TEA6422	AUDIO SWITCH IC FOR TV
SOUND MODULE	STV8258	DIGITAL AUDIO DECODER PROCESSOR
SOUND AMP	STA323W	DIGITAL AUDIO POWER AMPLIFIER
MICOM	S3F84BB	MICRO CONTROLLER

3. DMD Board

Items	Descriptions	Remarks
DMD Driver	DDP3021, TI	DLP Data Processor
Reset, Power	DAD2000, TI	DMD Power and Reset Driver
Power/Motor Controller	PMD1000, TI	12V VCM/Spindle Pre-Driver
Frame Buffer	MT49H8M36, MICOM	288M(8Mx), RCDRAM
Clock Generator	ICS640GI-41LF, IDT, TI	Spread spectrum Clock Generator
Program ROM	MX29LV320CBTC, macronix	32M(4Mx8 or 2Mx16), Flash Memory
LVDS Receiver	THC63LVD104, Thine	LVDS Digital Receiver, 75MHz

MEMO